

Quick Exhaust Valve

Pneumatic

1/4" FEMALE NPT, 150 PSI

Model 13QS1



Conforms to the SEP category of the European Pressure Equipment Directive
Issue No. 97/23/EC

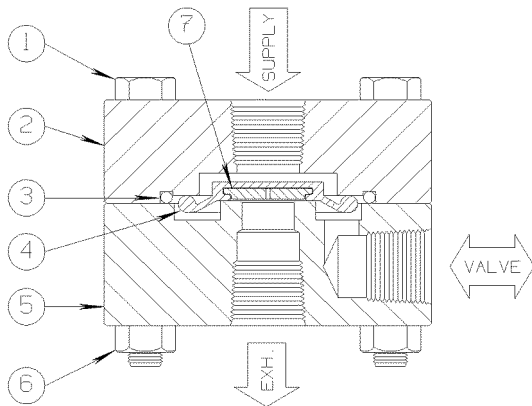

The **13QS1** is a two position, Flapper Seal operated, **high flow exhaust** control valve assembly. It establishes flow (from the inlet to outlet or Supply-to-Valve connections) to open a Surface Safety Valve (SSV or pneumatic Actuator), automatically with each application of operating pressure.

A loss or significant decrease of operating pressure will unseat the Flapper Seal quickly to establish high volume, reverse or Exhaust flow. Rapid closure of an Actuator valve is assured with the use of a Quick Exhaust Valve.

The Flapper Seal is manufactured from injection molded Viton material for long product life and reliability.

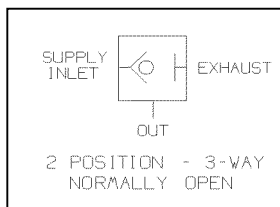

PARTS LIST:

1. Hex Bolt *
2. Upper Body
3. O Ring *
4. Viton Flapper Seal *
5. Lower Body
6. Hex Nut *
7. Flapper Seal Insert *

* Indicates parts included in a Repair Kit

Manufacturing Headquarters
1100 Valwood Parkway, Suite 112
Carrollton, TX 75006

SIGMA
VALVES

Tel: +1 (972) 446 8250
Fax: +1 (972) 446 8642
<http://www.sigmavalves.com>

Sigma Model Number 13QS1

1/4" FEMALE NPT, 150 PSI

Product Specifications

Flow Control Application: Normally Open

Control Function: Three-Way - Flapper Seal Operated

Flow Capacity: High Flow Service

Pressure Rating Body (Control Ports): 150 PSI maximum (10.34 bar)

Seal Material: Viton

Connection Size (Body): 1/4-18 Female N.P.T. (Supply, Valve, Exhaust)

Component Material (Metal): 316 Stainless Steel

Mounting: Field Mount

Orifice: 3/8 Diameter **Cv Factor:** .82

Weight: 1.9 Lbs.

Operating Temperature: -20° F to +250° F (-29° C to +121° C)

Overall Dimensions: 1-3/4 Height x 2-3/8 Diameter (4.45 cm Height x 6.03 cm Diameter)

Pressure Equipment Directive (PED): This product conforms to the SEP Category of the European P.E.D.

Installation and Maintenance Instructions:

Install between the interface valve and the actuator. This is done by threading the pipe or fitting from the control system into the port labeled "Supply". The piping from the actuator is threaded into the port labeled "Valve". A significant loss in pressure within the control system will trigger an exhaust of the actuator through the valve port and out the exhaust port. Sigma recommends the use of appropriate thread sealant for each port connection.

Shelf Position Port Status

Supply Inlet	Instrument supply pressure open to cylinder (SSV Actuator)
Valve	Outlet Pressure to cylinder (Closed to Exhaust Port)
Exhaust	Depressurizes cylinder upon loss of Supply Inlet

Repair Kit Information

Repair Kits contain all of the Seals and other components typically replaced when repairing the assembly. In order to maintain optimum operating control function, Sigma recommends changing the Repair Kit items once every two (2) years.