



ARRAY



Manufacturers and distributors of high quality gate valves for wellhead, manifold, distribution and fracture applications.

API 6A GATE VALVES



DEDICATED TO SERVICE

Whether you are a small independent operator or a diversified energy services company, Array is committed to being your valve partner.

ARRAY – DEDICATED TO SERVICE

In order to grow and profit in today's highly competitive oil and gas industry you need a valve supplier who can:

- Provide high-quality valves
- Deliver on schedule
- Respond to your unique requirements
- Help you profit from every project or order

Every Array associate, from our chief engineer to the man at the controls of the fork lift, spends all day, every day striving to meet these goals.

Our global sourcing network and domestic manufacturing facilities also ensure that Array has the ability to respond to both short and long term procurement horizons.

Array is committed to being your valve partner – a partner who delivers an unparalleled level of service and support at the most competitive price point in the industry.

YOUR VALVE PARTNER
IN TODAY'S COMPETITIVE
OIL AND GAS INDUSTRY.



TABLE OF CONTENTS

Our Environment – Make a Difference	5
Valve Trim Chart	7
2,000–5,000 PSI Expanding or Slab Gate Valves	10
10,000–15,000 PSI Expanding Gate Valves	12
10,000–15,000 PSI Slab Gate Valves	14
10,000–15,000 PSI Slab Gate Valves with Ball Screw	16
Recessed Body Dual Valves – Segmented Flange End	17
Recessed Body Dual Valves – Threaded End	18
Configuration Options for Array Gate Valves	20
Limited Warranty	22

TABLE OF CONTENTS FOR ARRAY GATE VALVES





At Array, producing quality gate valves is not just about ensuring customer satisfaction or enabling energy production – It is about preventing environmental damage.

The sole purpose of every gate valve manufactured or distributed by Array is to control the flow of volatile, often toxic, liquids and gases and keep them from being emitted into the atmosphere or spilled on the ground or into the water.

That is why every gate valve we sell is designed and manufactured to exceed standards set forth by the American Petroleum Institute (API) in Specification 6A, Latest Edition and why Array's quality systems and the quality systems of all of our suppliers are certified by API and/or the International Standards Organization (ISO).

It is also why we spend so much time working closely with our customers and suppliers to continuously improve the quality of our gate valves and the efficiency of our systems – because we recognize that the quality of our valves can positively impact the quality of our environment.

It is our primary concern and the reason we exist.

**OUR ENVIRONMENT
MAKE A DIFFERENCE**



VALVE TRIM CHART

		FORGED STEEL BODIES			CAST STEEL BODIES	
MATERIAL CLASS ¹		SERVICE CONDITION DESCRIPTION	MATERIAL ²	TEMP ³	MATERIAL ²	TEMP ³
AA	NON-SOUR SERVICE	GENERAL SERVICE STANDARD TRIM NON CORROSIVE	API 60K OR API 75K AISI 4130 ALLOY STEEL	AVAILABLE IN API TEMP L-Y	API 60K ASTM A487 CLASS 4 ALLOY STEEL	AVAILABLE IN API TEMP L-Y
BB		GENERAL SERVICE STAINLESS TRIM SLIGHTLY CORROSIVE	API 60K OR API 75K AISI 4130 ALLOY STEEL	AVAILABLE IN API TEMP L-Y	API 60K ASTM A487 CLASS 4 ALLOY STEEL	AVAILABLE IN API TEMP L-Y
CC		GENERAL SERVICE FULL STAINLESS MODERATELY CORROSIVE	API 75K AISI 410 STAINLESS STEEL	AVAILABLE IN API TEMP L-Y	API 75K ASTM A217 CA-15 STAINLESS STEEL	AVAILABLE IN API TEMP P-Y
DD-NL	SOUR SERVICE	SOUR SERVICE STANDARD TRIM NON CORROSIVE	API 60K OR API 75K AISI 4130 ALLOY STEEL	AVAILABLE IN API TEMP L-Y	API 60K ASTM A487 CLASS 4 ALLOY STEEL	AVAILABLE IN API TEMP L-Y
EE-0,5		SOUR SERVICE STAINLESS TRIM MODERATELY CORROSIVE	API 60K OR API 75K AISI 4130 ALLOY STEEL	AVAILABLE IN API TEMP L-Y	API 60K ASTM A487 CLASS 4 ALLOY STEEL	AVAILABLE IN API TEMP L-Y
EE-1,5		SOUR SERVICE STAINLESS TRIM MODERATELY CORROSIVE	API 60K OR API 75K AISI 4130 ALLOY STEEL	AVAILABLE IN API TEMP L-Y	API 60K ASTM A487 CLASS 4 ALLOY STEEL	AVAILABLE IN API TEMP L-Y
EE-NL		SOUR SERVICE STAINLESS TRIM MODERATELY CORROSIVE	API 60K OR API 75K AISI 4130 ALLOY STEEL	AVAILABLE IN API TEMP L-Y	API 60K ASTM A487 CLASS 4 ALLOY STEEL	AVAILABLE IN API TEMP L-Y
FF-0,5		SOUR SERVICE FULL STAINLESS HIGHLY CORROSIVE	API 75K AISI 410 STAINLESS STEEL	AVAILABLE IN API TEMP L-Y	API 75K ASTM A217 CA-15 STAINLESS STEEL	AVAILABLE IN API TEMP P-Y
FF-1,5		SOUR SERVICE FULL STAINLESS HIGHLY CORROSIVE	API 75K AISI 410 STAINLESS STEEL	AVAILABLE IN API TEMP L-Y	API 75K ASTM A217 CA-15 STAINLESS STEEL	AVAILABLE IN API TEMP P-Y
FF-NL		SOUR SERVICE FULL STAINLESS HIGHLY CORROSIVE	API 75K AISI 410 STAINLESS STEEL	AVAILABLE IN API TEMP L-Y	API 75K ASTM A217 CA-15 STAINLESS STEEL	AVAILABLE IN API TEMP P-Y

Notes: This trim chart provides information on materials included in standard valves offered by Array. Special materials, trims and configurations are available upon customer request. 10,000–15,000 psi slab gate valves and gate valves with ball screw operators have unique trim charts. Please refer to their respective section of the brochure for details.

1. Materials for sour service to latest edition of NACE MR0175. Alternate materials are available for special material classes designated by API or project requirements. Explanation of suffixes for material classes DD, EE and FF:

0,5 = 0.5 psia maximum partial pressure of H₂S.

1,5 = 1.5 psia maximum partial pressure of H₂S.

NL = no limit to H₂S.

API material class ZZ may be used when materials that have previously been used for sour service will not comply with current NACE MR0175/ISO standards.



BONNET ²	BONNET SEAL RING	EXPANDING OR SLAB GATE ⁴	STEM ⁵	SEAT ⁴
API 60K OR API 75K AISI 4130 ALLOY STEEL	AISI 1018/1020 LOW CARBON STEEL	ASTM A322 GR 4130 NITRIDED	ASTM A322 GR 4130 NITRIDED	ASTM A322 GR 4130 NITRIDED
API 60K OR API 75K AISI 4130 ALLOY STEEL	AISI 316 STAINLESS STEEL	AISI 410 STAINLESS STEEL NITRIDED	ASTM A564 GR 630 (17-4 PH) STAINLESS STEEL NITRIDED	AISI 410 STAINLESS STEEL NITRIDED
API 75K AISI 410 STAINLESS STEEL	AISI 316 STAINLESS STEEL	AISI 410 STAINLESS STEEL NITRIDED	ASTM A564 GR 630 (17-4 PH) STAINLESS STEEL NITRIDED	AISI 410 STAINLESS STEEL NITRIDED
API 60K OR API 75K AISI 4130 ALLOY STEEL	AISI 1018/1020 LOW CARBON STEEL	ASTM A322 GR 4130 NITRIDED	ASTM A322 GR 4130 NITRIDED	ASTM A322 GR 4130 NITRIDED
API 60K OR API 75K AISI 4130 ALLOY STEEL	AISI 316 STAINLESS STEEL	AISI 410 STAINLESS STEEL NITRIDED	ASTM A564 GR 630 (17-4 PH) STAINLESS STEEL NITRIDED	AISI 410 STAINLESS STEEL NITRIDED
API 60K OR API 75K AISI 4130 ALLOY STEEL	AISI 316 STAINLESS STEEL	AISI 410 STAINLESS STEEL NITRIDED	CORROSION RESISTANT ALLOY PER NACE	AISI 410 STAINLESS STEEL NITRIDED
API 60K OR API 75K AISI 4130 ALLOY STEEL	AISI 316 STAINLESS STEEL	AISI 410 STAINLESS STEEL NITRIDED	CORROSION RESISTANT ALLOY PER NACE	AISI 410 STAINLESS STEEL NITRIDED
API 75K AISI 410 STAINLESS STEEL	AISI 316 STAINLESS STEEL	AISI 410 STAINLESS STEEL NITRIDED	ASTM A564 GR 630 (17-4 PH) STAINLESS STEEL NITRIDED	AISI 410 STAINLESS STEEL NITRIDED
API 75K AISI 410 STAINLESS STEEL	AISI 316 STAINLESS STEEL	AISI 410 STAINLESS STEEL NITRIDED	CORROSION RESISTANT ALLOY PER NACE	AISI 410 STAINLESS STEEL NITRIDED
API 75K AISI 410 STAINLESS STEEL	AISI 316 STAINLESS STEEL	AISI 410 STAINLESS STEEL NITRIDED	CORROSION RESISTANT ALLOY PER NACE	AISI 410 STAINLESS STEEL NITRIDED

2. Charpy impact test results provided as required by API temperature rating and material class.

3. API temperature ratings X and Y require working pressure of valve to be de-rated as per API 6A annex G.

4. Nitriding is standard on all gates and seat. Hardfacing with tungsten carbide or HF6 also available upon request.

5. ASTM A564 Gr 630 (17-4 ph) HH1150 stems are not acceptable for sour service above 0.5 psia of H₂S. corrosion resistant alloys per NACE MR0175/ISO standards are recommended

6. Teflon inserts standard – metal to metal seats used if requested by customer or for equipment manufactured for use in elevated temperature service (API temp ratings X & Y)

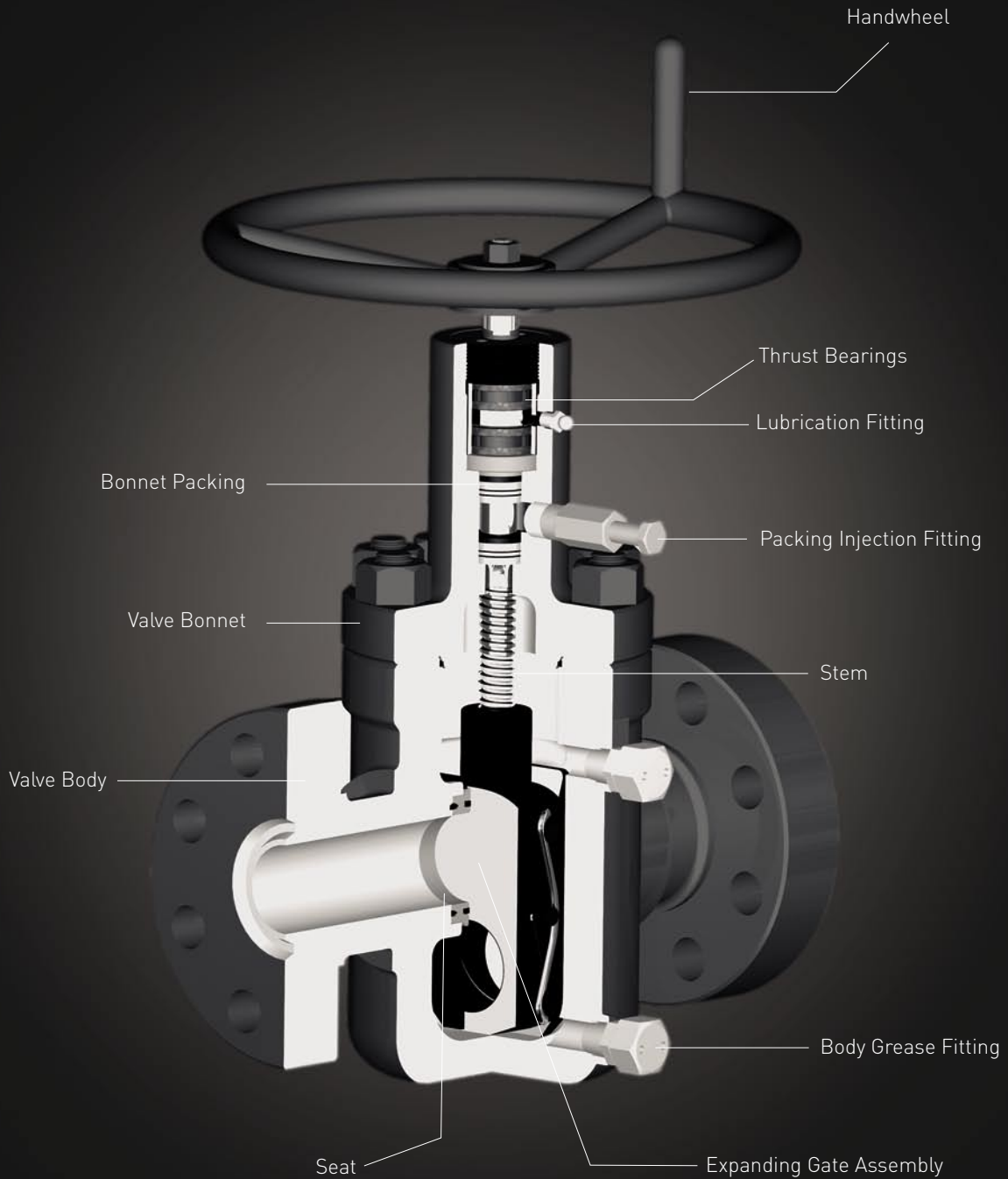

Array 2,000–5,000 psi expanding and slab gate valves are available with either cast or forged steel valve bodies and bonnets. They are used in a variety of wellhead and distribution applications.



2,000 – 5,000 PSI EXPANDING OR SLAB GATE VALVES

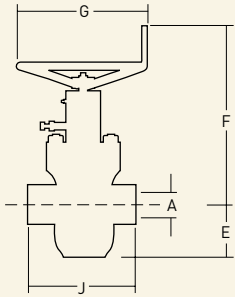

THREADED VALVES

SIZE	Working (PSI)	A		E		F		G		J		WT		N
		in	mm	in	mm	in	mm	in	mm	in	mm	lbs	kgs	
2 1/16	2000,	2.06	52	4.81	122	19.25	488	11.00	279	9.62	244	90	40	13
	3000-5000	2.06	52	5.06	128	19.43	493	13.00	330	9.62	244	125	56	
2 9/16	2000,	2.56	65	5.62	142	20.18	512	13.00	330	10.25	260	125	56	15-1/2
	3000-5000	2.56	65	5.93	150	20.43	519	16.00	406	10.25	260	160	72	
3 1/8	2000,	3.12	79	6.93	176	22.50	571	13.00	330	11.37	288	190	86	20
	3000-5000	3.12	79	7.31	185	22.75	577	16.00	406	11.37	288	230	104	
4 1/16	2000,	4.06	103	8.62	219	25.93	658	16.00	406	13.00	330	320	145	24-1/2
	3000-5000	4.06	103	9.06	230	26.37	669	20.00	508	13.00	330	420	190	

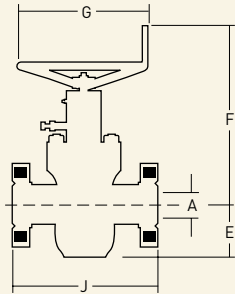

FLANGED END VALVES

SIZE	Working (PSI)	A		E		F		G		J		WT		N
		in	mm	in	mm	in	mm	in	mm	in	mm	lbs	kgs	
2 1/16	2000	2.06	52	4.81	122	19.25	488	11.00	279	11.62	295	120	54	13
	3000-5000	2.06	52	5.06	128	19.43	493	13.00	330	14.62	371	180	56	
2 9/16	2000	2.56	65	5.62	142	20.18	512	13.00	330	13.12	333	180	81	15-1/2
	3000-5000	2.56	65	5.93	150	20.43	519	16.00	406	16.62	422	220	99	
3 1/8	2000	3.12	79	6.93	176	22.50	571	13.00	330	14.12	358	220	99	20
	3000	3.12	79	7.31	185	22.75	577	16.00	406	17.12	434	300	136	
	5000	3.12	79	7.31	185	22.75	577	16.00	406	18.62	437	340	154	
4 1/16	2000	4.06	103	8.62	219	25.93	658	16.00	406	17.12	358	360	163	24-1/2
	3000	4.06	103	9.06	230	26.37	669	20.00	508	20.12	511	520	235	
	5000	4.06	103	9.06	230	26.37	669	20.00	508	21.62	549	560	254	
5 1/8	2000	5.12	130	11.62	295	32.50	825	21.00	533	22.12	561	800	362	31
	3000	5.12	130	11.62	295	32.50	825	23.50	596	24.12	612	900	408	
	5000	5.12	130	11.62	295	32.50	825	23.50	596	28.62	727	980	444	
7 1/16	2000	7.06	179	13.87	352	33.10	840	13.00	330	20.00	666	1021	463	42
	3000	7.06	179	13.87	352	34.10	866	16.00	406	24.00	714	1118	507	
	5000	7.06	179	13.87	352	34.10	866	20.00	508	30.00	812	1398	634	

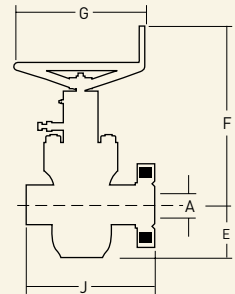

THREADED BY FLANGED VALVES

SIZE	Working (PSI)	A		E		F		G		J		WT		N
		in	mm	in	mm	in	mm	in	mm	in	mm	lbs	kgs	
2 1/16	2000	2.06	52	4.81	122	19.25	488	11.00	279	10.62	269	105	47	13
	3000-5000	2.06	52	5.06	128	19.43	493	13.00	330	12.12	307	140	63	
2 9/16	2000	2.56	65	5.62	142	20.18	512	13.00	330	11.67	296	155	70	15-1/2
	3000-5000	2.56	65	5.93	150	20.43	519	16.00	406	13.43	341	190	86	
3 1/8	2000	3.12	79	6.93	176	22.50	571	13.00	330	12.75	323	205	92	20
	3000	3.12	79	7.31	185	22.75	577	16.00	406	14.25	344	265	120	
	5000	3.12	79	7.31	185	22.75	577	16.00	406	15.00	344	285	129	
4 1/16	2000	4.06	103	8.62	219	25.93	658	16.00	406	15.06	382	340	154	24-1/2
	3000	4.06	103	9.06	230	26.37	669	20.00	508	16.56	420	470	213	
	5000	4.06	103	9.06	230	26.37	669	20.00	508	17.31	439	490	222	

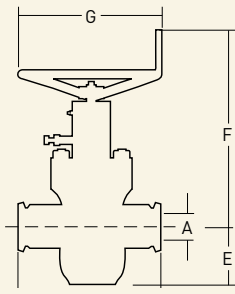

CLAMP HUB END VALVES

SIZE	Working (PSI)	A		E		F		G		J		WT		N	Hub Size
		in	mm	in	mm	in	mm	in	mm	in	mm	lbs	kgs		
2 1/16	2000	2.06	52	4.81	122	19.25	488	11.00	279	11.20	279	84	38	13	B-20
	3000-5000	2.06	52	5.06	128	19.43	493	13.00	330	11.25	287	105	47		
2 9/16	2000	2.56	65	5.62	142	20.18	512	13.00	330	12.00	304	109	49	15-1/2	C-25
	3000-5000	2.56	65	5.93	150	20.43	519	16.00	406	15.00	381	159	72		
3 1/8	2000	3.12	79	6.93	176	22.50	571	13.00	330	14.00	355	168	76	20	D-31
	3000	3.12	79	7.31	185	22.75	577	16.00	406	17.00	431	215	97		
	5000	3.12	79	7.31	185	22.75	577	16.00	406	17.00	431	222	100		
4 1/16	2000	4.06	103	8.62	219	25.93	658	16.00	406	16.00	406	310	140	24-1/2	E-42
	3000	4.06	103	9.06	230	26.37	669	20.00	508	18.00	457	396	179		
	5000	4.06	103	9.06	230	26.37	669	20.00	508	19.00	482	408	185		

N=Number of turns to open valve

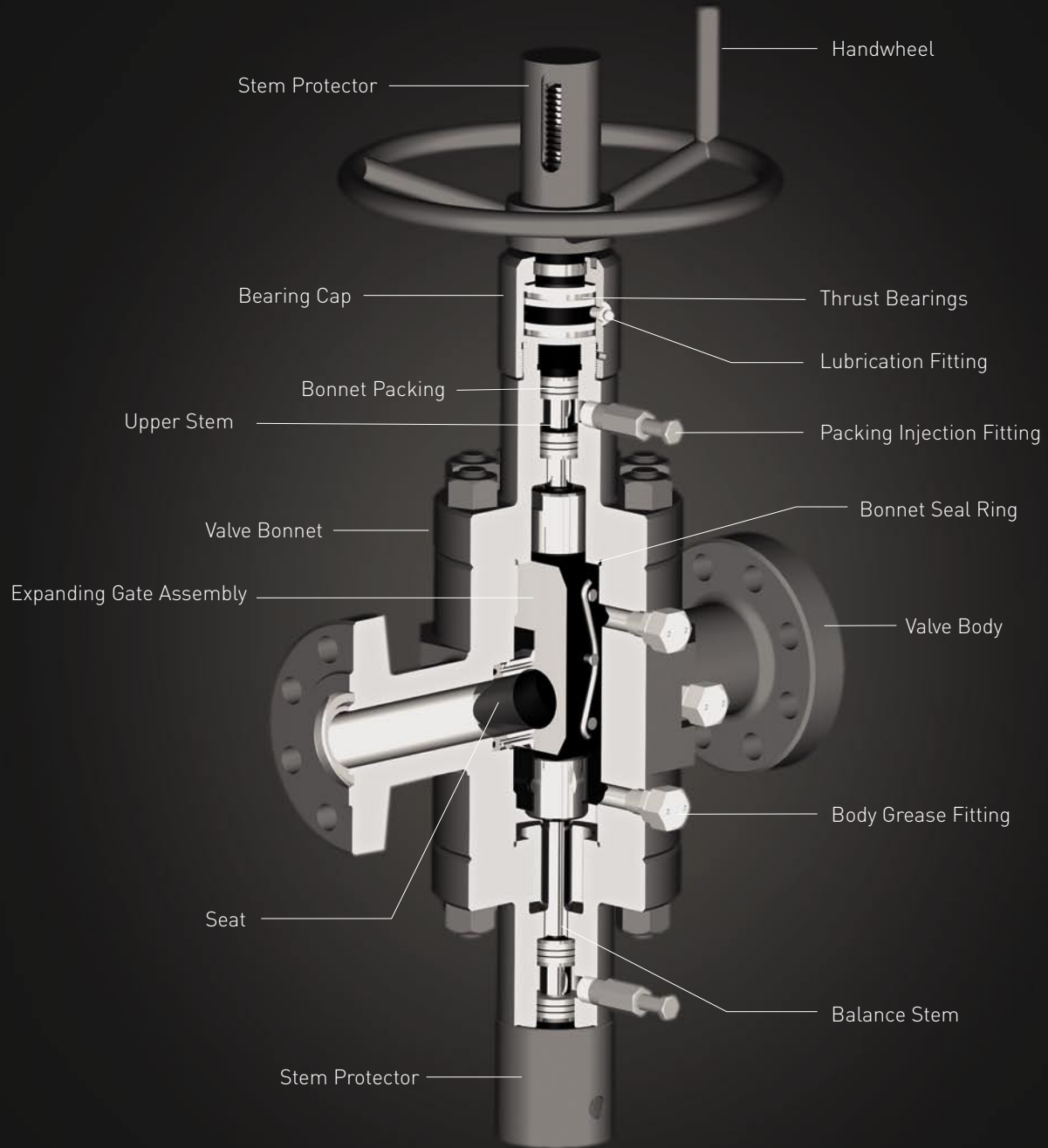

Array 10,000 –15,000 psi expanding gate valves come standard with forged steel valve bodies and bonnets. They are used in a variety of wellhead and distribution applications.



10,000–15,000 PSI EXPANDING GATE VALVES

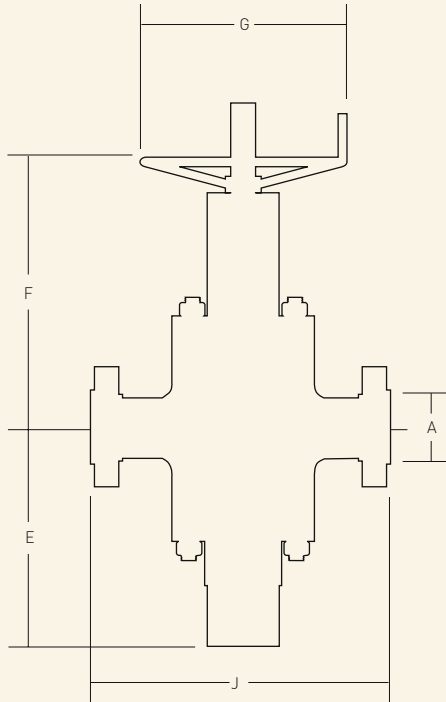

- A Valve Bore
- E Bore centerline to bottom of valve
- F Bore centerline to handwheel top
- G Handwheel diameter
- J Flange face to face
- N Number of turns to open valve
- WT Estimated weight

10,000 PSI VALVES

SIZE	J		A		E		F		G		WT		N
	in	mm	in	mm	in	mm	in	mm	in	mm	lbs	kgs	
1 13/16	18.25	463	1.81	46	14.5	368	21.50	546	12.00	305	280	127	12
2 1/16	20.50	520	2.06	52	16.00	406	23.00	584	14.00	356	490	222	14
2 9/16	22.25	565	2.56	65	18.00	635	25.00	635	20.00	508	570	258	15
3 1/16	24.37	619	3.06	77	21.00	533	29.00	736	22.00	559	850	385	18
4 1/16	26.37	670	4.06	103	26.50	673	36.00	914	26.00	660	1080	489	23

15,000 PSI VALVES

SIZE	J		A		E		F		G		WT		N
	in	mm	in	mm	in	mm	in	mm	in	mm	lbs	kgs	
1 13/16	18.00	457	1.81	46	14.75	374	22.00	558	14.00	356	380	172	12
2 1/16	19.00	482	2.06	52	16.25	412	23.80	603	18.00	457	520	235	14
2 9/16	21.00	533	2.56	65	19.00	482	26.50	673	20.00	508	760	344	15
3 1/16	23.56	598	3.06	77	21.00	539	29.00	762	22.00	584	850	458	18
4 1/16	29.00	736	4.06	103	26.75	679	36.30	920	26.00	660	1929	585	23

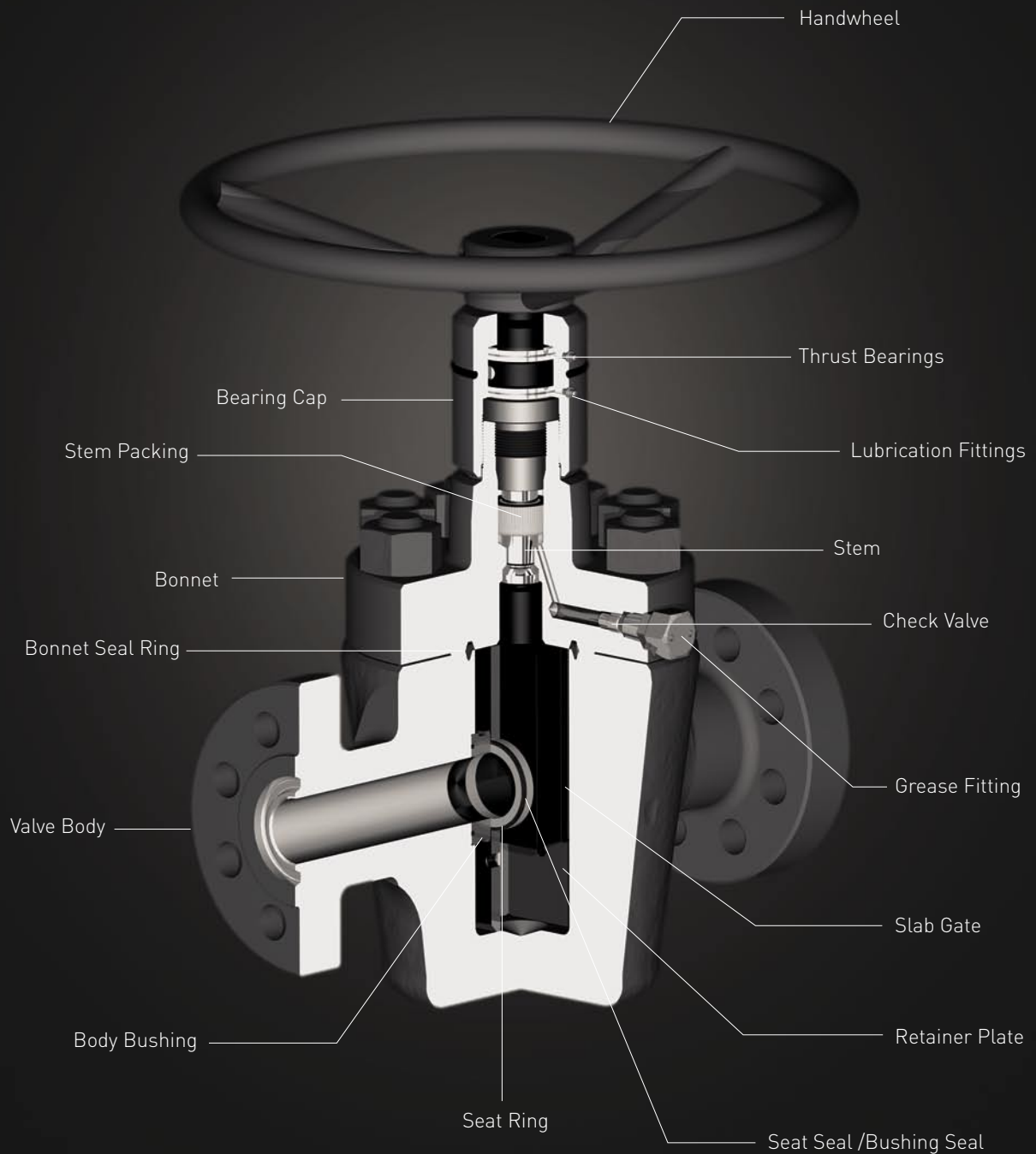

Array 10,000–15,000 psi slab gate valves come standard with forged steel valve bodies and bonnets. They are used in a variety of wellhead, distribution and manifold applications.



10,000–15,000 PSI SLAB GATE VALVES

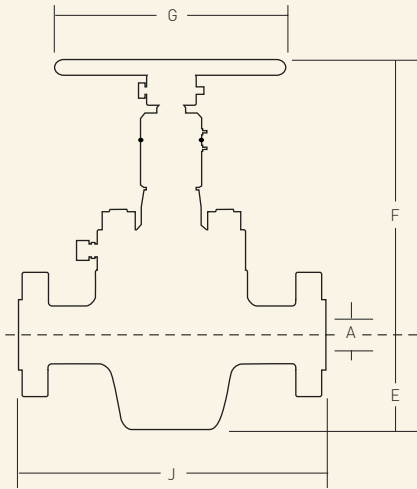

- A Valve bore
- E Bore centerline to bottom of valve
- F Bore centerline to handwheel top
- G Handwheel diameter
- J Flange face to face
- N Number of turns to open valve
- WT Estimated weight

SIZE	PRESS	A		E		F		G		J		WT		N
		in	mm	in	mm	in	mm	in	mm	in	mm	lbs	kgs	
1 13/16	10,000	1.81	46	5.69	144	16.47	418	14.00	355	18.25	463	240	108	12
	15,000	1.81	46	5.90	149	16.73	425	18.00	431	18.00	457	300	136	12
2 1/16	10,000	2.06	52	5.69	144	16.45	417	14.00	355	20.50	520	265	120	12
	15,000	2.06	52	5.90	149	16.73	425	18.00	431	19.00	482	330	149	12
2 9/16	10,000	2.56	65	6.75	171	17.68	448	18.00	431	22.25	565	370	167	15
	15,000	2.56	65	7.74	196	18.95	481	18.00	431	21.00	533	450	204	15
3 1/16	10,000	3.06	77	8.12	206	18.58	471	24.00	584	24.38	619	520	235	18
	15,000	3.06	77	9.65	245	22.79	578	24.00	584	23.56	598	880	399	19
4 1/16	10,000	4.06	103	10.19	258	21.42	544	24.00	584	26.38	670	850	385	23
	15,000	4.06	103	11.71	297	24.05	636	24.00	584	29.00	736	1360	616	24

COMPONENT	STANDARD	FULL STAINLESS	STANDARD WITH HARDFACING	FULL STAINLESS WITH HARDFACING
	API MATERIAL CLASS: EE-0,5	API MATERIAL CLASS: FF-0,5	API MATERIAL CLASS: EE-NL	API MATERIAL CLASS: FF-NL
	MATERIAL	MATERIAL	MATERIAL	MATERIAL
BODY	AISI 4130 75K	AISI 410 SS 75K	AISI 4130 75K	AISI 410 SS 75K
BONNET	AISI 4130 75K	AISI 410 SS 75K	AISI 4130 75K	AISI 410 SS 75K
GATE	AISI 410 SS 75K NITRIDED	AISI 410 SS 75K NITRIDED	AISI 4130 75K HARDFACED	AISI 410 SS 75K HARDFACED
SEAT RING	AISI 410 SS 75K NITRIDED	AISI 410 SS 75K NITRIDED	SOLID STELLITE #6 (1)	SOLID STELLITE #6 (1)
SEAT SEAL	GTFE	GTFE	GTFE	GTFE
BODY BUSHING	AISI 410 SS 75K	AISI 410 SS 75K	AISI 410 SS 75K	AISI 410 SS 75K
BODY BUSHING SEAL	GTFE	GTFE	GTFE	GTFE
STEM	17-4 PH HH1150	17-4 PH HH1150	INCONEL 718 (2)	INCONEL 718 (2)
BONNET SEAL RING	AISI 316 SS	AISI 316 SS	AISI 316 SS	AISI 316 SS
RETAINER PLATE	AISI 316 OR 304 SS	AISI 316 OR 304 SS	AISI 316 OR 304 SS	AISI 316 OR 304 SS
STUDS	B7M / L7M	B7M / L7M	B7M / L7M	B7M / L7M
NUTS	2HM	2HM	2HM	2HM

(1) Stellite is a registered trademark of the Deloro Stellite Group
(2) Inconel is a registered trademark of Special Metals Corporation

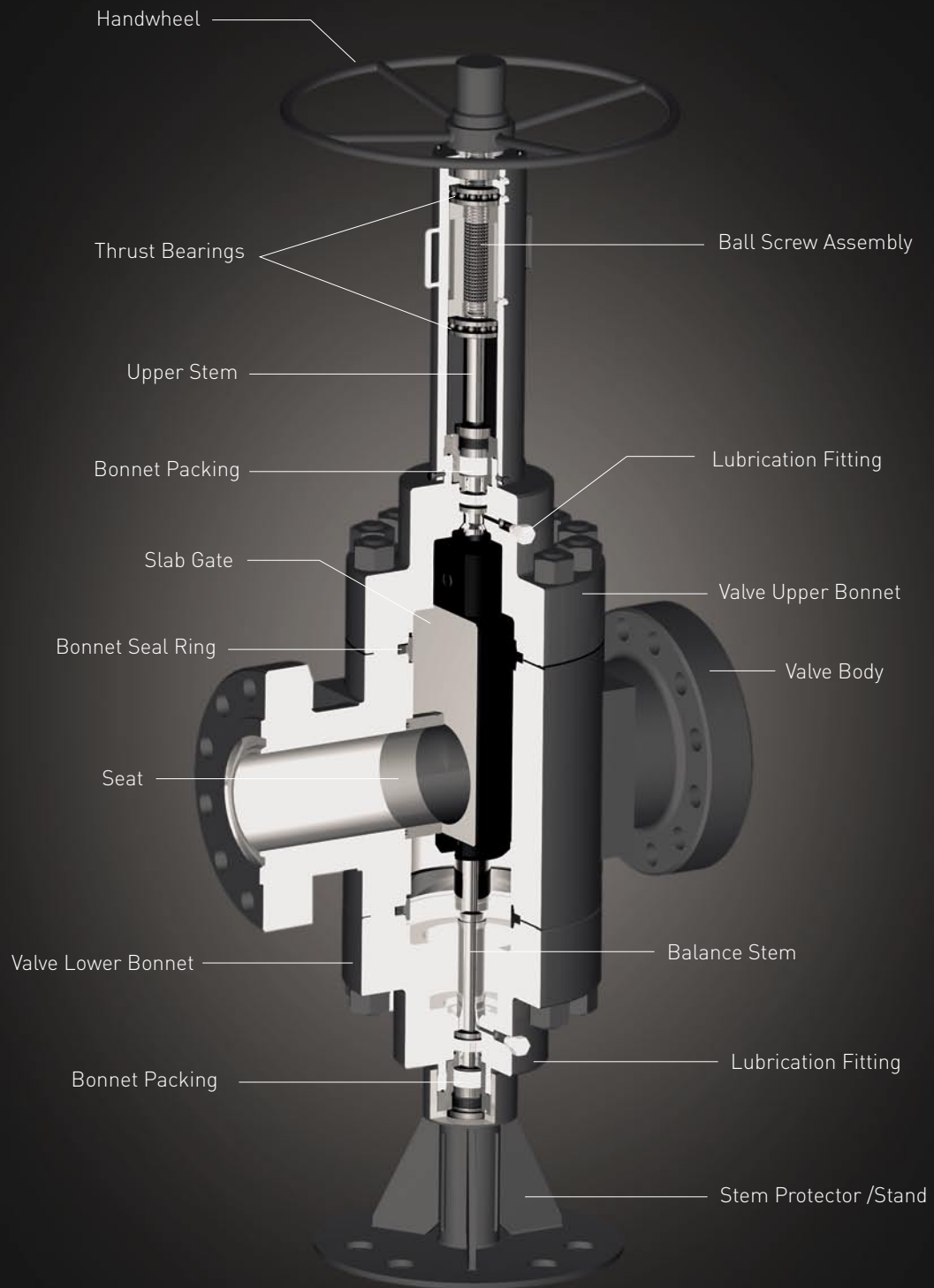

Array 10,000–15,000 psi slab gate valves have ball screw operators to reduce the torque required to open or close the valve under pressure. They come standard with forged valve bodies and bonnets as well as hardfaced gates and seats for durability. These features make them well suited for well fracture applications.



10,000-15,000 PSI SLAB GATE VALVES WITH BALL SCREW

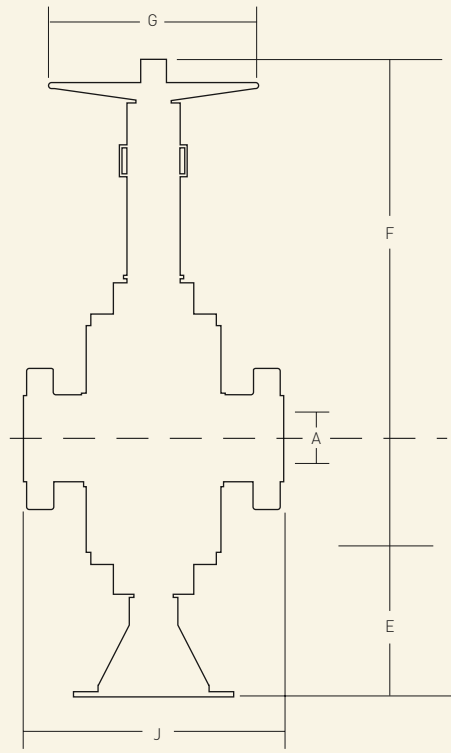

- A Valve Bore
- E Bore centerline to bottom of valve
- F Bore centerline to handwheel top
- G Handwheel diameter
- J Flange face to face
- N Number of turns to open valve
- WT Estimated weight

SIZE	PRESS	A		E		F		G		J		WT		N
		in	mm	in	mm	in	mm	in	mm	in	mm	lbs	kgs	
5 1/8	10,000	5.12	130	29.59	751	45.20	1148	28.00	711	29.00	736	2304	860	12
7 1/8	10,000	7.06	179	34.74	882	51.28	1302	28.00	711	35.00	889	3804	1420	16

COMPONENT	STANDARD WITH HARDFACING	FULL STAINLESS WITH HARDFACING	STANDARD WITH INCONEL AND HARDFACING	FULL STAINLESS WITH INCONEL AND HARDFACING
	MATERIAL	MATERIAL	MATERIAL	MATERIAL
BODY	AISI 4130 75K	AISI 410 SS 75K	AISI 4130 75K	AISI 410 SS 75K
BONNET	AISI 4130 75K	AISI 410 SS 75K	AISI 4130 75K	AISI 410 SS 75K
GATE	AISI 410 SS 75K HFTC	AISI 410 SS 75K HFTC	AISI 410 SS 75K HFTC	AISI 410 SS 75K HFTC
SEAT	AISI 410 SS 75K HFTC	AISI 410 SS 75K HFTC	AISI 410 SS 75K HFTC	AISI 410 SS 75K HFTC
SEAT SEAL	GTFE/HSN BACKUP	GTFE/HSN BACKUP	GTFE/HSN BACKUP	GTFE/HSN BACKUP
STEM - UPPER & LOWER	17-4 PH HH1150	17-4 PH HH1150	INCONEL 718 (1)	INCONEL 718 (1)
BONNET SEAL RING	AISI 316 SS/AISI 410 SS	AISI 316 SS/AISI 410 SS	AISI 316 SS/AISI 410 SS	AISI 316 SS/AISI 410 SS
STUDS	B7M / L7M	B7M / L7M	B7M / L7M	B7M / L7M
NUTS	2HM	2HM	2HM	2HM

(1) Inconel is a registered trademark of Special Metals Corporation

RECESSED BODY DUAL VALVES – SEGMENTED FLANGED END

Recessed body dual valves are available with both cast and forged steel bodies and bonnets. They are manufactured as ordered to comply with specific project requirements.

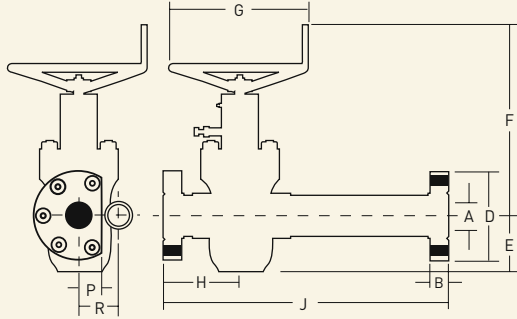

Sizes: 2 1/16", 2 9/16", 3 1/8"

Working Pressures: 2,000, 3,000 and 5,000 PSI

N=number of turns to open.

Specify Valve 1A, 2A, 1B or 2B.

SIZE	A		E		F		G		H		J		P		R		WT		N
	in	mm	in	mm	in	mm	in	mm	in	mm	in	mm	in	mm	in	mm	lbs	kgs	
2 1/16	2.06	52	5.06	128	19.43	493	13.00	330	7.31	185	24	609	2.23	56	3.54	90	135	61	13
2 9/16	2.56	65	5.93	150	20.43	519	16.00	406	8.31	211	24	609	2.68	68	4.5	114	195	88	15-1/2
3 1/8	3.12	79	7.31	185	22.75	577	16.00	406	9.31	236	27	704	3.78	96	5.04	128	300	136	20

VALVE CONFIGURATIONS

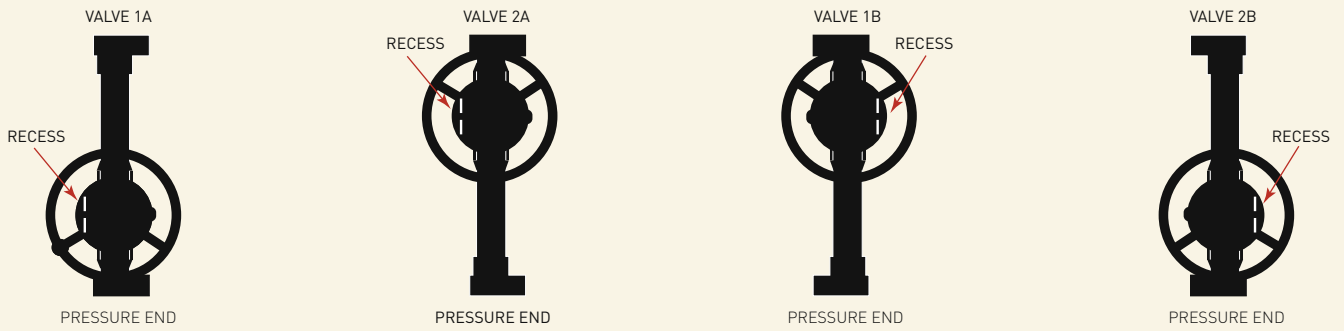

ASSEMBLY STYLES

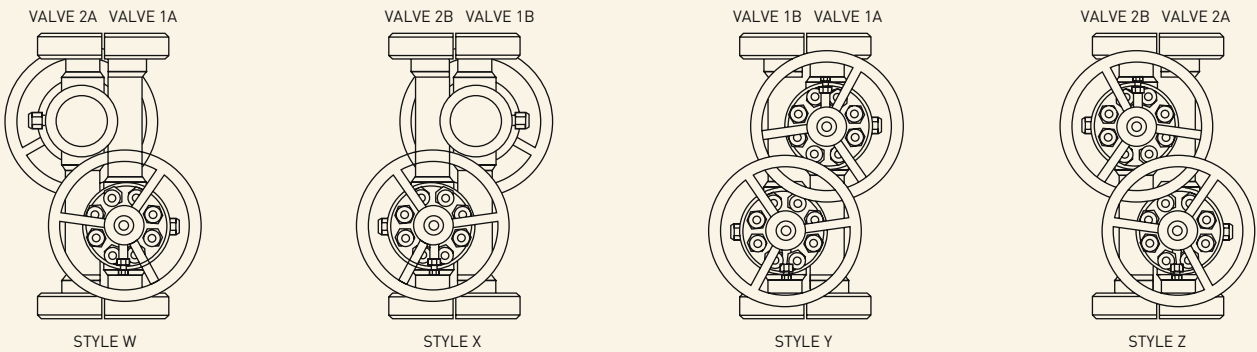



RECESSED BODY DUAL VALVES – THREADED END

Recessed body dual valves are available with both cast and forged steel bodies and bonnets. They are manufactured as ordered to comply with specific project requirements.

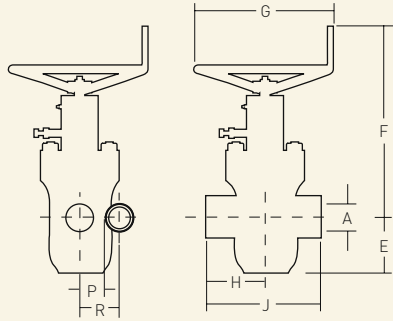

Sizes: 2 1/8", 2 3/8", 3 1/8"

Working Pressures: 2,000, 3,000 and 5,000 PSI

N=number of turns to open.

SIZE	A		E		F		G		H		J		P		R		WT		N
	in	mm	in	mm	in	mm	in	mm	in	mm	in	mm	in	mm	in	mm	lbs	kgs	
2 1/8"	2.06	52	5.06	128	19.43	493	13.00	330	4.81	122	9.32	244	2.23	56	3.54	90	97	44	13
2 3/8"	2.56	65	5.93	150	20.43	519	16.00	406	5.12	130	10.25	260	2.68	68	4.50	114	117	53	15
3 1/8"	3.12	79	7.31	185	22.75	577	16.00	406	5.68	144	11.37	288	3.78	96	5.04	128	215	97	20

THREADED END VALVE CONFIGURATIONS

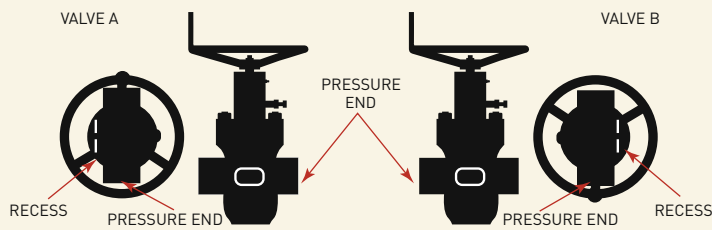

ASSEMBLY STYLES

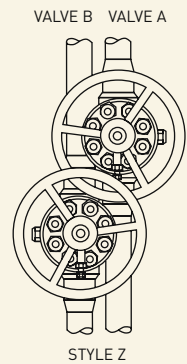
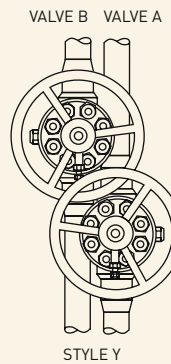
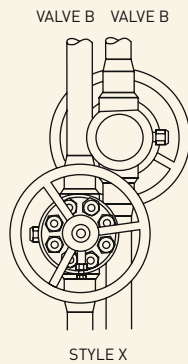
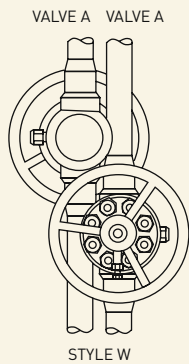



Slab Gate

Available for 10,000 - 15,000 psi valves



Slab Gate

Available for 2,000 - 5,000 psi valves



Expanding Gate

Available for 2,000 - 15,000 psi valves



Cast Gate Valve Body

Standard on 2,000 - 5,000 psi valves
Not available for 10,000 - 15,000 psi valves

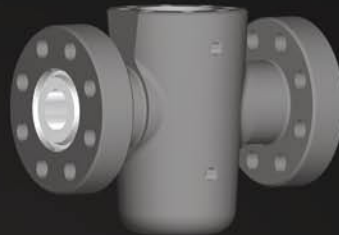

Forged Gate Valve Body

Standard on 10,000 - 15,000 psi valves
Also available for 2,000 - 5,000 psi valves



APH

Hydraulic/Spring Return



APHD

Hydraulic/Double Acting



APHW

Hydraulic/Wirecutting/Spring Return



APD

Pneumatic Diaphragm



APP

Pneumatic Piston



API 6A gate valves from Array can be provided in a variety of configurations based on project requirements or customer preference. A general description of some of the major configuration options appears below. Please see trim chart for additional information.

Slab Gate – 10,000 – 15,000 psi valves

Offered in Array's 10,000 and 15,000 psi slab gate valves, the parallel slab gate offers bi-directional sealing capabilities ideal for wellhead and manifold applications.

Slab Gate – 2,000–5,000 psi valves

Offered in Array's 5,000 psi slab gate valves, the slab gate offers bi-directional sealing capabilities and is preferred by some end users.

Expanding Gate – 2,000–15,000 psi valves

Offered in Array's 2,000–15,000 psi gate valves, the expanding gate is the most popular gate we offer because it allows for a positive seal between gate and both seats even at extremely low pressures.

Cast Gate Valve Body – 2,000–5,000 psi valves

Offered in Array's 2,000–5,000 psi gate valves, the cast valve body is the most popular body we offer for 5,000 psi and below wellhead gate valves. It is very cost effective and offers extremely reliable service.

Forged Gate Valve Body – 2,000–15,000 psi valves

Offered in Array's 2,000–15,000 psi gate valves, the forged valve body is standard on all 10,000 and 15,000 psi gate valves. Some end users also prefer a forged body for wellhead applications where pressures are 5,000 psi and below.

Safety Valves – Actuated Valves and Actuated Bonnets

Array offers a complete line of hydraulic and pneumatic actuators. These can be delivered as complete actuated valve assemblies, as actuator and bonnet assemblies ready to mount on any manufacturer's valve or as gate valves prepared for actuators provided from any actuator manufacturer. For more information please see Array's API 6A & 6D Actuation Brochure.

CONFIGURATION OPTIONS FOR ARRAY GATE VALVES



DEDICATED TO SUPPORT

Array Products stands firmly behind every gate valve we sell or distribute. If you have a problem with the quality of any of our products or their shipment to you, contact Array and we will immediately work to solve it.



LIMITED WARRANTY

The following warranty is exclusive and in lieu of all other warranties whether express, implied or statutory, including, but not by way of limitation, any warranty or merchantability or fitness for any particular purpose.

Array Products warrants to each original buyer of products manufactured by Array that such products are free from defects in material and workmanship under normal use and service for a period of one (1) year from the date of shipment provided that no warranty is made in respect to: Any product which has been repaired or altered in such a way in Array's judgement, as to effect the product adversely; Any product which has in Array's judgement, been subject to negligence, accident or improper storage. Any product which has not been operated or maintained in accordance with normal practice and in conformity with recommendations and public specifications of Array.

Array's obligation under this warranty is limited to use reasonable efforts to repair, replace or at its option, refunding the purchase price. The cost of labor for installing

a repaired or replacement product shall be borne by the purchaser. Replacement parts provided under the terms of this Warranty are warranted for the remainder of the warranty period of the products upon which they were installed to the same extent as if such parts were original components thereof. Warranty serviced provided hereunder do not assume any liability for damages caused by any delays involving warranty service.

For complete specification information, prices and name, address and telephone number of the Array representative nearest you, call or write to us at the address below.

FOR WARRANTY OR SHIPMENT INFORMATION:

Attention: Logistics & Quality Manager
quality@arrayproducts.com

FOR SALES OR SPECIFICATION INFORMATION:

Attention: Sales Manager
info@arrayproducts.com

**ARRAY HOLDINGS, INC., D.B.A.
ARRAY PRODUCTS**

4520 E Chandler Road
Muskogee, Oklahoma 74403

Toll Free: 866.445.1837 • Phone: 918.682.7952 • Fax: 918.682.7904 • www.arrayproducts.com



YOUR **VALVE PARTNER**
IN TODAY'S COMPETITIVE
OIL AND GAS INDUSTRY.

ARRAY HOLDINGS, INC., D.B.A.
ARRAY PRODUCTS

4520 E Chandler Road
Muskogee, Oklahoma 74403

Toll Free: 866.445.1837 • Phone: 918.682.7952 • Fax: 918.682.7904 • www.arrayproducts.com